



**OPERATOR'S MANUAL**  
**SELF-LOADING COMBO TRAILER**  
**MODEL #CT2710C-LT-SL**

6" PIPE MAXIMUM

# TABLE OF CONTENTS

## OPERATOR'S MANUAL

### Equipment Safety

Safety Alerts	1-1
Read & Understand	1-1
General Safety	1-2
Wear Safety Equipment	1-2
Units With Hydraulics	1-2
Keep Personnel Away	1-3
Where to Stand	1-3
Cutting Steel Bands	1-3
Operator's Seat	1-3
Gas Powered Units	1-4
Fuel Handling	1-4
Carbon Monoxide	1-4
Have Tires Properly Serviced	1-5

### Overview

Stringing & Planting Pipe	2-1
Stringing & Plowing Pipe	2-2
Straightening Pipe for Relining	2-2
Straightening Pipe for Directional Boring	2-2
Hydraulic Power Unit	2-3
Fuel Valve	2-3
Engine Control Lever	2-3
Hydraulic Fluid	2-3

### Transporting

Lock Machine	3-1
Read Before Towing Trailer	3-1

# TABLE OF CONTENTS

## OPERATOR'S MANUAL

### Operation

Important	4-0
Instructions	4-1
Coil & Combo Trailer – Loading Instructions	4-2
Loading Coil	4-3
Threading Pipe through LineTamer®	4-4
Threading Pipe through LineTamer® (cont'd)	4-5

### Maintenance

Maintenance	5-1
Washing the Machine	5-1
Check Hydraulic Fluid	5-1
Brake System	5-1
Grease	5-2
Grease Bearing and Sleeves	5-2
Tire Pressure	5-3

### Hydraulic Fluid

Characteristics	6-1
-----------------	-----

### Raise or Lower Mast

Without Hydraulic Mast Cylinder	6-2
With Optional Hydraulic Mast Cylinder	6-3

### To Attach Cable to Coil **7-1**

### Specifications

### Warranty

### Tulsa Winch Manual

# EQUIPMENT SAFETY

## Safety Alerts

This hazard alert sign  appears in this manual. When you see this sign, carefully read what it says. **YOUR SAFETY IS AT STAKE.**

You will see the hazard alert sign with these words: **DANGER, WARNING, and CAUTION.**

### **DANGER**

Indicates an imminently hazardous situation which, if not avoided, will result in death or serious injury.

### **WARNING**

Indicates a potentially hazardous situation which, if not avoided, could result in death or serious injury.

### **CAUTION**

Indicates a hazardous situation which, if not avoided, may result in minor or moderate injury.

In this manual you should look for two other words: **NOTICE** and **IMPORTANT.**

**NOTICE:** can keep you from doing something that might damage the machine or someone's property. It may also be used to alert against unsafe practices.

**IMPORTANT:** can help you do a better job or make your job easier in some way.

## Read and Understand

Do not operate this equipment until you have carefully read, and understand the "Safety" and "Operation" sections of this manual, and all other equipment manuals that will be used with it.

Your safety and the safety of others depends upon care and judgment in the operation of this equipment.

Follow all applicable federal, state, local, and industry specific regulations.

We cannot anticipate every possible circumstance that might involve a potential hazard. The warnings in this manual and on the machine are therefore not all inclusive. You must satisfy yourself that a procedure, tool, work method, or operating technique is safe for you and others. You should also ensure that the machine will not be damaged or made unsafe by the method of operation or maintenance you choose.



# EQUIPMENT SAFETY

## General Safety

Safety is important. Report anything unusual that you notice during set up or operation.

**LISTEN** for thumps, bumps, rattles, squeals, air leaks, or unusual sounds.

**SMELL** odors like burning insulation, hot metal, burning rubber, hot oil, or natural gas.

**FEEL** any changes in the way the equipment operates.

**SEE** problems with wiring and cables, hydraulic connections, or other equipment.

**REPORT** anything you see, feel, smell, or hear that is different from what you expect, or that you think may be unsafe.



## Wear Safety Equipment

Wear a hard hat, safety shoes, safety glasses, and other applicable personal protective equipment.

Remove jewelry and rings, and do not wear loose-fitting clothing or long hair that could catch on controls or moving machinery.



## Units With Hydraulics

Although the hydraulic pressures in this machine are low compared to some hydraulically operated equipment, it is important to remember that a sudden hydraulic oil leak can cause serious injury, or even be fatal if the pressure is high enough.

**⚠ WARNING** *Escaping fluid under pressure can penetrate the skin causing serious injury. Keep hands and body away from pinholes which eject fluid under pressure. Use a piece of cardboard or paper to search for leaks. If any fluid is injected into the skin, it must be immediately removed by a doctor familiar with this type of injury.*

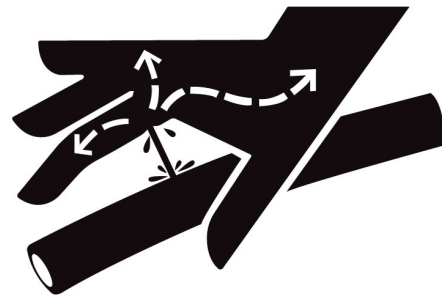

**NOTICE:** Wear safety glasses, and keep face clear of area when bleeding air from hydraulic system to avoid spraying oil into eyes.

## Keep Personnel Away

**⚠️ WARNING**

The rollers in this machine are under hydraulic pressure and can cause severe bodily harm. All personnel must keep hands and body away from moving parts of machine.

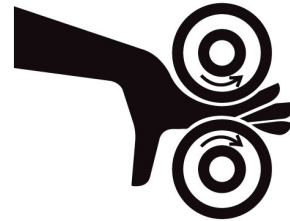

## Where to Stand

All non-participating personnel should be at least 15 feet away from pipe coil and machine during pull.

**⚠️ WARNING**

Coiled pipe can uncoil unexpectedly, posing a safety hazard for anyone in close proximity. Stay away from pipe coil and machine during pull to avoid injury.



## Cutting Steel Bands

**⚠️ WARNING**

Coiled pipe can uncoil with considerable force, causing extreme bodily injury if not properly contained. Do not cut the steel straps around the coil until the coil is contained in a suitable reel trailer or coil cage.

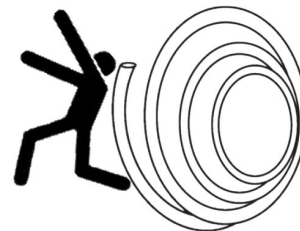

Leave plastic straps on coil. Do not cut.

## Operator's Seat

Always operate the machine from the control side with the operator in the control seat. Use the seat belt at all times.

Never stand on the LineTamer® during operation.



## Gas Powered Units

**⚠ DANGER** Gasoline engines will cause explosions when operated in a hazardous environment. Do not operate gas powered machines in a hazardous environment.

Do not place flammable substances near the engine while it is operating.

A spark arrester is available as an optional part for this engine. It is illegal in some areas to operate an engine without a spark arrester. Check local laws and regulations before operating.



## Fuel Handling

**⚠ DANGER** Gasoline and diesel fuel are extremely flammable and their vapors will explode if ignited.

Do not fill the fuel tank while the engine is hot or running, as spilled fuel could ignite.

Refuel in a well ventilated area. Do not smoke or allow flames or sparks in the area where the engine is refueled, or where gasoline is stored.

Do not start the engine near spilled fuel. Wipe up spills immediately.

Make sure the fuel tank cap is closed and properly secured.

Avoid repeated or prolonged contact with skin or breathing of vapor.

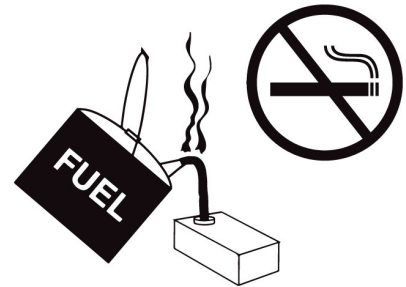

## Carbon Monoxide

**⚠ DANGER** Engine exhaust gases contain poisonous carbon monoxide. Carbon monoxide can cause severe nausea, fainting and death. Avoid inhaling exhaust fumes and never run the engine in a closed or confined area.



## Have Tires Properly Serviced

**⚠️ WARNING**

Failure to follow proper procedures when mounting a tire on a wheel or rim can produce an explosion which may result in serious injury or death. Have tires mounted by someone that is experienced, and has the proper equipment to perform the job safely.

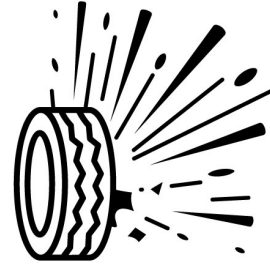



# OVERVIEW

## USAGE OPTIONS

1. Pulling pipe from the LineTamer® and stringing the pipe on the ground for direct burial (in the trench) or relining an existing pipeling
2. Pulling LineTamer® behind vehicle with pipe reel or cage for stringing out straightened pipe along right of way.
3. Pulling LineTamer® behind vehicle with plowing vehicle pulling pipe directly into the ground.
4. Stationary: LineTamer® connected to coil trailer with plowing vehicle pulling a pipe directly into the ground.
5. Stationary: LineTamer® connected to a coil trailer with pipe being pulled through existing pipe for relining.
6. Stationary: LineTamer® connected to a coil trailer with directional boring unit pulling pipe directly into the ground.

## I: Stringing Pipe

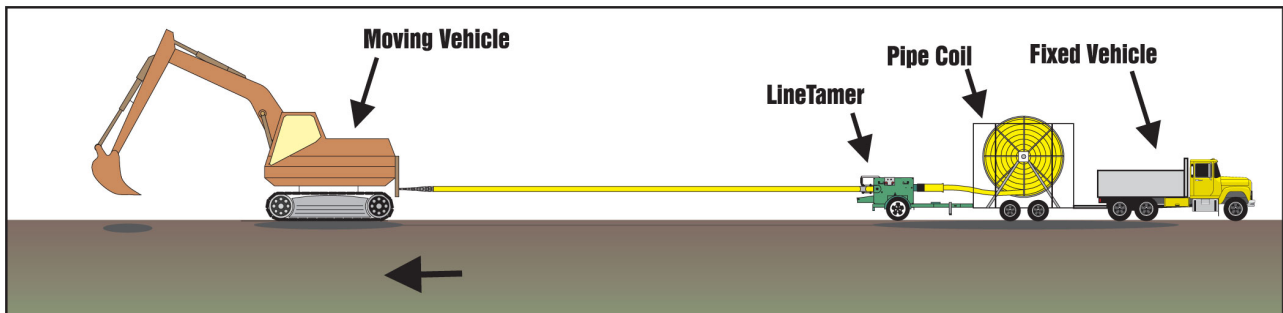

## II: Stringing Pipe

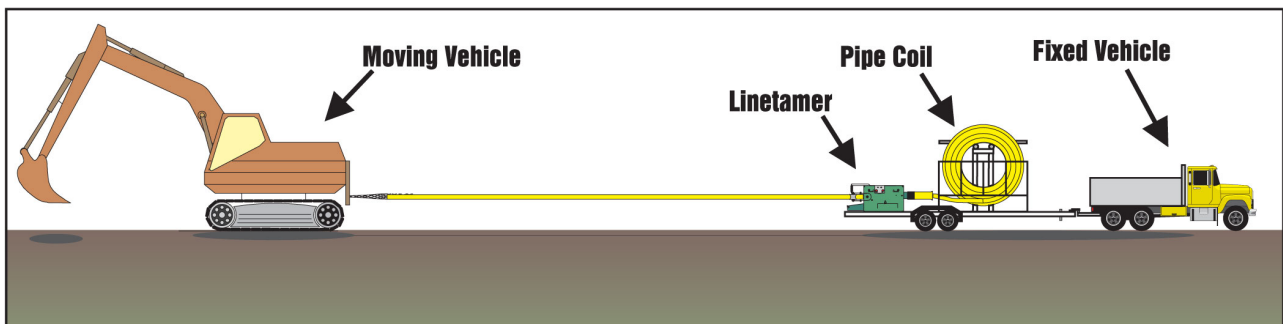

## III: Stringing & Planting Pipe

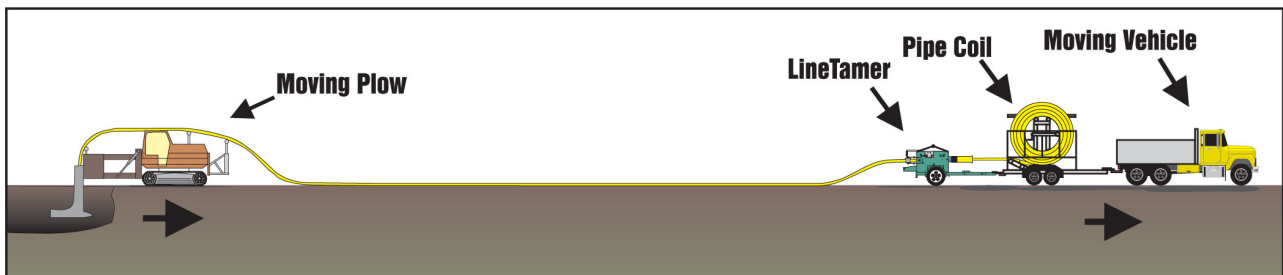

# OVERVIEW

## IV: Stringing & Plowing Pipe

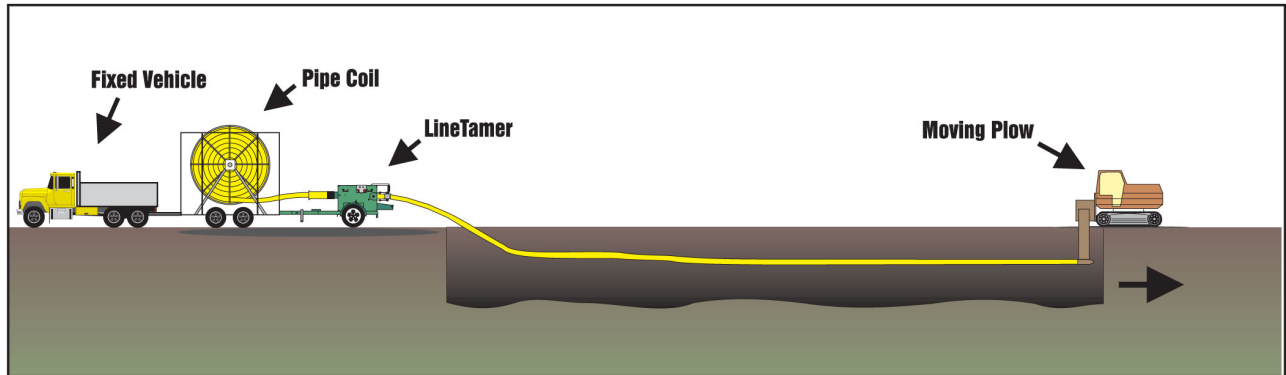

## V: Straightening Pipe for Relining

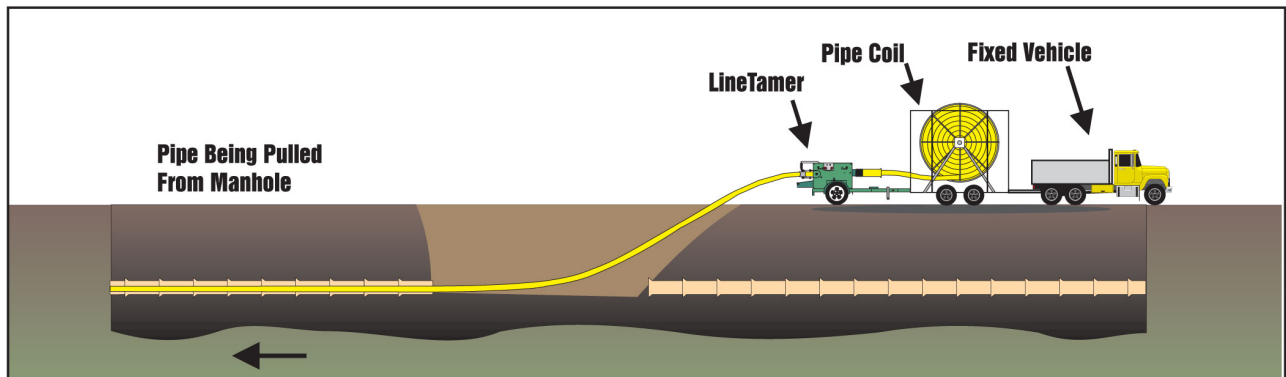

## VI: Straightening Pipe for Directional Boring

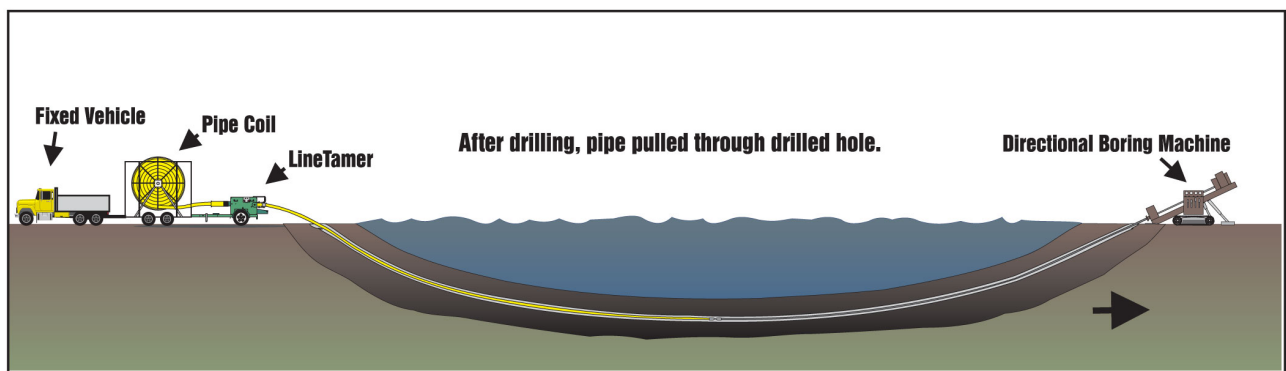

# OVERVIEW

## Hydraulic Power Unit

- (A) Hydraulic fluid fill.
- (B) Gasoline fill.
- (C) Starter rope.
- (D) Engine oil check and fill.
- (E) System pressure gauge

The hydraulics are an open center flow system. The pressure relief valve is set at 2500 psi.



## Fuel Valve

The fuel valve should be turned off when transporting the equipment, or when not being used.

Turn the valve control in to turn off. Turn the control out to turn on.



## Engine Control Lever

All the way back to the left, shuts the engine off.

All the way forward to the right, is the choke position. Between these two positions, the desired engine speed can be set.

**IMPORTANT:** Do not use the choke if the engine is warm or the ambient temperature is high.



## Hydraulic Fluid

Check fluid level in reservoir. Proper level is indicated on the sight gauge. If level drops below this point, fill reservoir to the HIGH level on the sight gauge. Refer to the "Hydraulic Fluids" section of this manual for hydraulic oil recommendations.

Never allow dirt or other foreign matter to enter the open tank.



# TRANSPORTING

## Lock Machine

Disconnect coil pipe from preparation machine.

Install the yellow-colored transport locking pin to prohibit movement of pipe guide.

Move seat to position inside trailer and lock into place.



## Read Before Towing Trailer

Never tow a trailer before you check to be sure of the following.

- Electric brakes are operating properly.
- Break away switch cable is safely attached to tow vehicle.
- Coupler and safety chains are safely secured to hitch.
- Trailer jack is in the raised position.
- Check all fasteners for proper tightness.
- Wheel lug nuts are properly tightened.
- Wheel bearings are properly adjusted and maintained.
- Load is within maximum load carrying capacity.
- Tires are properly inflated.
- All trailer lighting is working properly.

Follow all federal, state local and industry standards when towing a trailer.



## IMPORTANT

***PIN MUST ALWAYS BE FULLY INSERTED INTO BREAKAWAY SWITCH. REMOVING PIN (AS SHOWN) WILL ACTIVATE BRAKES, & MAY DAMAGE TIRES, BRAKES, BATTERY, WIRING, & OTHER PARTS.***



**SAFETY FIRST!**

# IMPORTANT

Always wear Safety Harness  
(Not Provided)

Attached to Hook

When Climbing on Trailer

Never Climb when Trailer is Operating



# INSTRUCTIONS

## LOADING INSTRUCTIONS

### **ALL PERSONNEL MUST STAND CLEAR OF COIL WHILE LOADING.**

PULL TRAILER ALONG SIDE OF COILED PIPE & BEYOND ENOUGH TO OPEN GATE.

BE SURE COIL IS POSITIONED FOR PIPE TO UNCOIL FROM BOTTOM TO REAR

OPEN GATE FULLY AND BACK TRAILER TO CENTER OF COIL..

REMOVE OUTRIGGER SAFETY CHAINS & PINS AND PULL OUT ABOUT 3 1/2 FEET.  
LOWER TO GROUND.

KEEP TENSION ON CABLE TO KEEP IT PROPERLY COILED ON WINCH DRUM.

1. PUSH "ARM" "DN" LEVER AND "CABLE" "DN" LEVER FORWARD AS NECESSARY TO POSITION FOR LOADING.
2. ATTACH CABLE TO COILED PIPE BY PLACING CABLE AROUND PIPE AND HOOKING TO CABLE TO FORM A CHOKER (MOST EASILY DONE BY THROWING ROPE WITH LOOP OVER COIL & HOOKING CABLE IN LOOP: THEN PULL ROPE BACK.) (BE SURE PIPE IS PROTECTED FROM CABLE BY RUBBER COVERING.)
3. PULL "CABLE" "UP" LEVER FULLY TOWARD YOU AND HOLD THERE THROUGH OUT LOADING.
4. WHEN COIL HAS BEEN LIFTED TO THE CORRECT HEIGHT TO CLEAR THE SUPPORT ROLLERS, WHILE CONTINUING TO HOLD FULL BACK ON "CABLE" "UP" LEVER, PARTIALLY PULL "ARM" "UP" LEVER TOWARD YOU, AS COIL MOVES HORIZONTALLY, MAINTAIN HEIGHT BY MOVING "ARM" LEVER AS NECESSARY.
5. WHEN THE ARM IS VERTICAL AND THE SIDE OF THE COIL TOUCHES THE ARM, RELEASE BOTH LEVERS.
6. PUSH "CABLE". "DN" LEVER FORWARD UNTIL COIL IS SUPPORTED BY ROLLERS.
7. PULL "CABLE" "UP" LEVER & "ARM" "UP" LEVER TOWARD YOU AS NECESSARY TO "STORE" ARM WHILE KEEPING SLIGHT TENSION ON CABLE.
8. WHEN ARM IS IN "STORED" POSITION, PULL "CABLE" "UP" LEVER TOWARD YOU TO PULL COIL TO PROPER POSITION.
9. REMOVE CABLE FROM COIL AND SECURE.

# COIL & COMBO TRAILER

## LOADING INSTRUCTIONS

### Raise Mast

Use a lifting device to raise or lower the mast and rollers to the height required by the coil being used. The channels that the mast slides on have holes to insert pins through to hold the mast up.

Raise the mast above the desired pin location. Insert the pins through the channel. Place the spacers on the pins and secure in place with locking pins. Lower the mast to rest on top of the pins.

**IMPORTANT:** The mast should be raised and lowered without a coil of pipe loaded. The added weight of the pipe will cause the mast to bind, making it difficult to raise and lower.

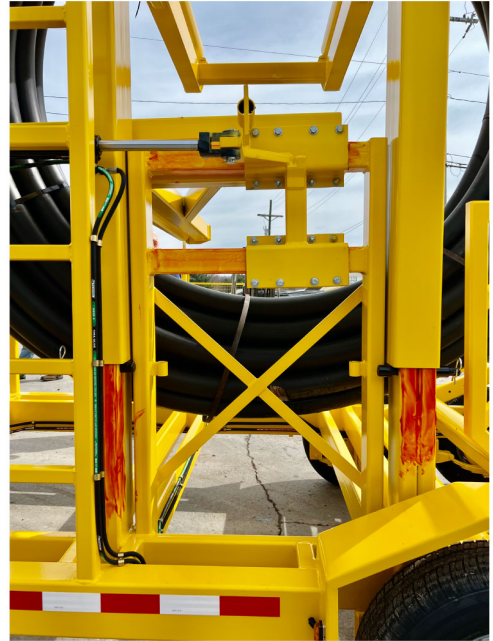

### Load Coil

Unpin and swing side gate out on trailer.

Lift pipe coil up with a sling onto top rollers. Move coil all the way back on the rollers. If using a forklift, protect the pipe from being damaged by the forks.

Close side gate and pin in position.



# LOADING COIL

## Interior Coil Roller

The interior coil roller can be adjusted using the hydraulic control lever.

The roller should be adjusted until it butts up against the inside of the coil.



## Narrow Coils

**NOTICE:** The side gate must be positioned close enough to the coil to contain it from the side.

The side gate can be unpinned and moved back to a narrower position when required to contain the coil.

Reinstall pins after moving.

### To position gate:

- (1) Open gate fully.
- (2) Lift end of gate to relieve pressure on pins.  
(2 men may be required)
- (3) Remove both pins and while lifting end of gate, slide gate in or out as necessary to desired position.
- (4) Reinstall pins after moving.

ALWAYS ADJUST GATE AS CLOSE TO COIL AS POSSIBLE.





# THREADING PIPE

## Loading Pipe into LineTamer®

Install pulling head in pipe.

Raise threading rollers to highest position and manually roll pipe beneath #1 threading roller.

Attach pulling strap to pulling head.

**NOTICE:** Use only soft straps or rope to avoid any sharp edges which can damage rollers.

Lower threading roller #1 to align pipe with LineTamer pipe guide.

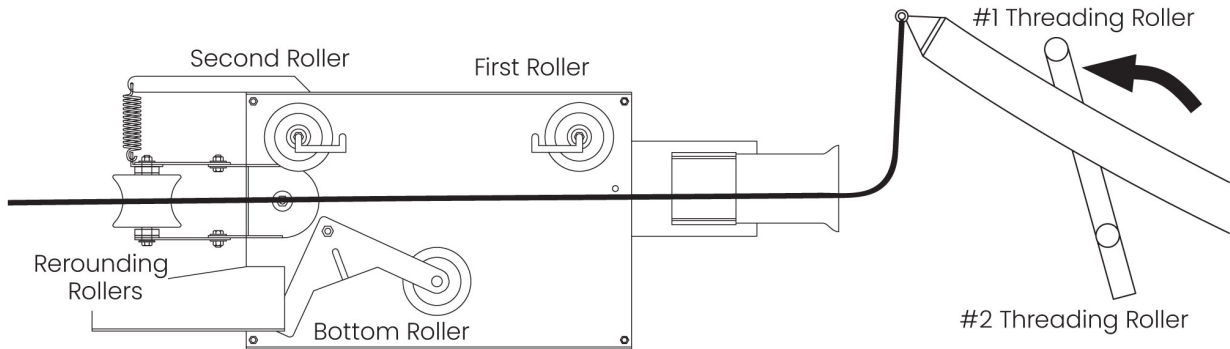

Pull pipe just past the first roller and stop.

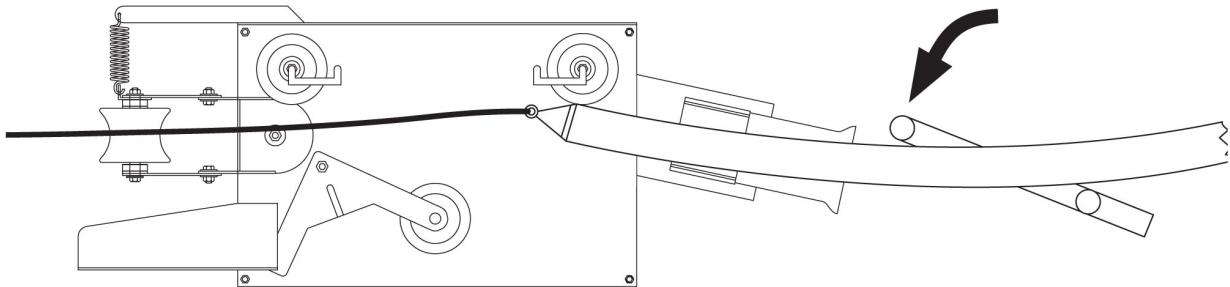

Raise threading roller #2 to align pipe with second roller.

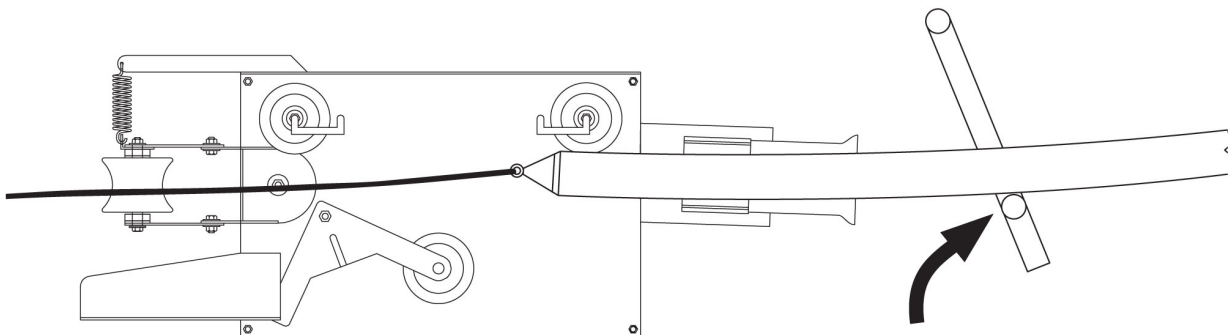

# THREADING PIPE

## Loading Pipe into the LineTamer® (continued)

Pull pipe just past the second roller and stop.

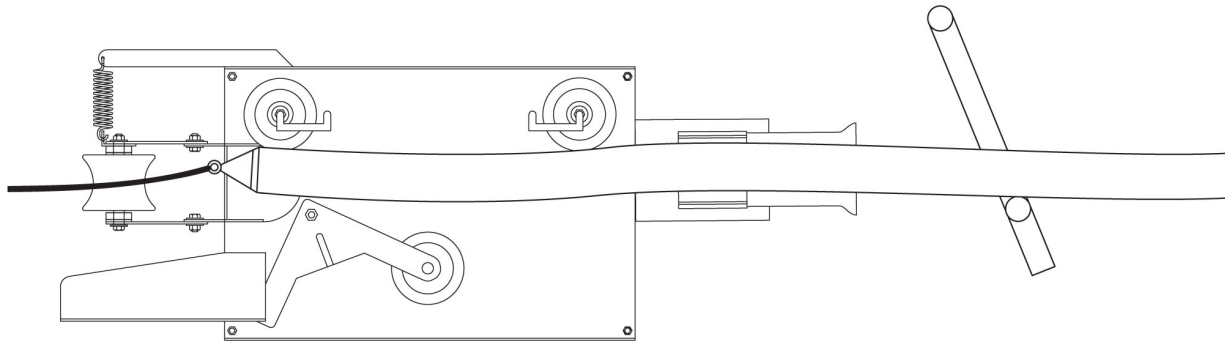

Raise bottom roller in the LineTamer® to align pipe with the re-rounding rollers and pull pipe through.

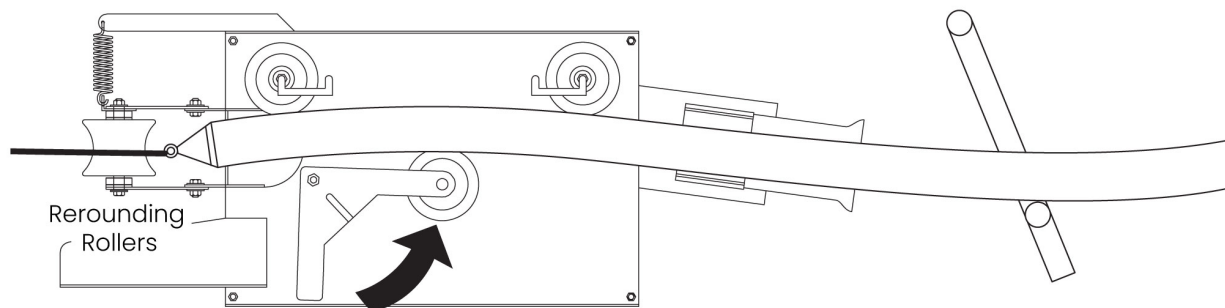

**Important:** The use of a pulling head while loading pipe in the machine may pose a damage potential to the rollers. Many pulling heads have strap edges and hard metal surfaces that could collide with the rollers and cause damage.

An alternative would be to use a strap and rope to pull and align the pipe in the machine.

To use the strap and rope to load the pipe in the machine, drill a hole about 2 to 3 inches from the end of the pipe. Thread the rope through the hole and attach to the strap (as shown). The Strap and rope will pull the pipe downward and forward. This downward force makes it easier to pass each of the rollers in the LineTamer®.

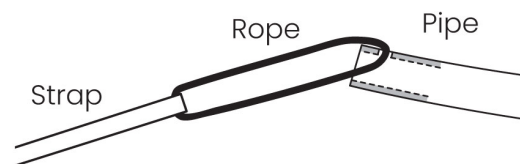

We recommend a pulling head to payout the coil of pipe as it provides means of attaching to the pipe.

If a pulling head is not available, you can use a similar arrangement of the strap and rope. Drill two holes inline about 2 to 3 inches from the end of the pipe. Thread the rope through both holes and attach the strap. Use the strap to pull the pipe to payout the coil.



# MAINTENANCE

## Preventative Maintenance

To insure optimum performance, the machine must be kept clean and well maintained.

With reasonable care, this machine will give years of service. Therefore, it is important that a regular schedule of preventive maintenance be kept.

Store machine inside, out of the weather, whenever possible.



## Washing the Machine

An important factor in the service life of this machine is cleanliness. The machine should be cleaned with soap and water as needed.

When exposed to dust and mud in a field location, the machine should be washed at the end of each days work.



## Check the Hydraulic Fluids

Periodically check the hydraulic fluid level in reservoir. All hydraulic cylinders must be retracted before checking fluid to get an accurate level. Maintain fluid at HIGH Level.

Never allow dirt or foreign matter to enter the open tank.

Refer to the "Hydraulic Fluids" section of this manual for hydraulic oil recommendations.



## Brake System

Periodically check electric brake breakaway switch battery for full charge.

Check wires and connections to brakes for damage. Repair or replace parts as required.



# MAINTENANCE

## Grease

All moving parts should be greased periodically. All pipe rollers have fittings for lubricating the bearings. Grease the fittings once a month, or as required.



Grease sliding linkage of rerounder system.



Check axles for grease. Follow manufacturer's recommendations in front of right fender.

Check the grease level in your Trailer Buddy Axle before you launch.

If the blue Auto Check ring is visible you do not need to add grease.



## Grease Bearings and Sleeves

Periodically grease all fittings for bearings and sleeves.



# MAINTENANCE

## Air Pressure

Air Pressure in tires should be maintained according to the PSI rating located on the tire.



# HYDRAULIC FLUIDS

The use of proper hydraulic fluid is mandatory to achieve maximum performance and machine life. Use a clean, high quality, anti-wear hydraulic fluid with a viscosity index (VI) of 135 minimum. It should have a maximum viscosity of 500 cSt (2000 SSU) at startup (ambient temperature) and a minimum viscosity of 13 cSt (65 SSU) at the maximum fluid temperature (generally 80°F above ambient). Using hydraulic fluids that do not meet these criteria may cause poor operation and/or damage to the hydraulic components.

The following table specifies the fluid temperature at various viscosities. Temperature rise of the hydraulic fluid can vary from 30°F to about 80°F over the ambient temperature depending on the pressure setting, age of the pump, wind, etc. Mobil Unavis N46 hydraulic fluid is installed at our factory. The advantage of this fluid is a wider temperature range, however, this fluid should not be used for continuous operation below 24°F

Hydraulic Fluids Characteristics																	
Manufacturer	Fluid Name	cSt 100F	cSt 210F	V.I.	-20F	-10F	0F	10F	30F	50F	70F	90F	110F	130F	150F	Range °F	Range °C
Mobil	DTE 10 Excel 15	15.8	4.1	168	*****	*****	*****	*****	*****	*****	*****	*****	*****	*****	*****	-16 - 113	-27 - 45
	DTE 10 Excel 32	32.7	6.6	164				*****	*****	*****	*****	*****	*****	*****	*****	12 - 154	-11 - 68
	DTE 10 Excel 46	45.6	8.5	164				*****	*****	*****	*****	*****	*****	*****	*****	23 - 173	-5 - 7
	DTE 10 Excel 68	68.4	11.2	156				*****	*****	*****	*****	*****	*****	*****	*****	37 - 196	3 - 91
	Unavis N-32	34.9	6.9	164				*****	*****	*****	*****	*****	*****	*****	*****	12 - 150	-11 - 66
	Unavis N-46	46	8.5	163				*****	*****	*****	*****	*****	*****	*****	*****	24 - 166	-4 - 74
	Unavis N-68	73.8	12.1	160				*****	*****	*****	*****	*****	*****	*****	*****	39 - 193	4 - 89

**NOTE:** This chart is based on pump manufacturer recommendations of 13 to 500 cSt.

**NOTE:** Temperatures shown are fluid temperatures. – NOT ambient temperatures.

# OPERATING THE MAST

## RAISE AND LOWER MAST

(Without Hydraulic Mast Cylinder)

**While Unloaded ONLY**  
**With Loading Arm Retracted**

1. REMOVE CABLE FROM LOADING ARM.
2. LOWER HOOK & CABLE BETWEEN WINCH DRUM & REAR WINCH MOUNT ON REAR SIDE OF ARM.
3. PASS CABLE AROUND PULLY AT BOTTOM OF MAST.
4. HOOK CABLE LOOP (NOT HOOK) OVER HANGER (IN FRONT OF TENSION ROLLER HYDRAULIC CYLINDER MOUNT) WITH HOOK TOWARD FRONT, AS SHOWN IN PICTURE.
5. PULL "CABLE" "UP" LEVER TO RAISE MAST AND EXPOSE MAST HEIGHT ADJUSTMENT PIN HOLES.

*TWO HEIGHT ADJUSTMENT HOLES ONLY ARE AVAILABLE  
DO NOT GO HIGHER SAYOTS -Tulsa Winch.*

6. PLACE PINS IN HOLES & INSTALL SAFETY PINS.
7. LOWER MAST ONTO PINS & REPLACE CABLE ON ARM.



# OPERATING THE MAST

## RAISE AND LOWER MAST

(With Hydraulic Mast Cylinder – HMI Option)

**While Unloaded ONLY**

**With Loading Arm Retracted**



1. Open Gate
2. Pull Mast Lever to Raise Mast
3. Place Pins in Selected Height Holes
4. Take Pressure off Mast Cylinder by Lowering Onto Safety Pins



# ATTACHING CABLE

## TO ATTACH CABLE TO COIL IN VERTICAL POSITION

**NOTE:** REQUIRES A 3/8" X 20' ROPE WITH LOOP ON ONE END

1. **HELPER** – STANDING INSIDE TRAILER, THROW ROPE (ATTACHED TO CABLE HOOK) OVER LOADING ARM PIVOT TUBE TO PLACE CABLE OUTSIDE TRAILER.
2. **OPERATOR** – RELEASES WINCH CLUTCH OR PUSHES "CABLE" "DN" LEVER PAY OUT CABLE, AS HELPER KEEPS CABLE TAUNT.
3. **OPERATOR** – EXTENDS LOADING ARM.
4. **HELPER** – STANDING INSIDE TRAILER, LOOP ROPE AROUND CABLE & HOLD ENDS TO ALLOW CABLE TO BE PULLED WITHIN REACH, TO BE HOOKED IN STEP 6.
5. **OPERATOR** – UNHOOKS ROPE AND CARRIES HOOK & CABLE AROUND AND THROUGH PIPE COIL AND HOOKS INTO ROPE EYE.
6. **HELPER** – PULLS BOTH ENDS OF ROPE AND ATTACHES HOOK OVER CABLE TO MAKE CHOKER AROUND PIPE, MOVES OUTSIDE TRAILER, AND STEADIES PIPE WHILE LOADING.
7. **OPERATOR** – LOADS PIPE. (SEE LOADING INSTRUCTIONS)

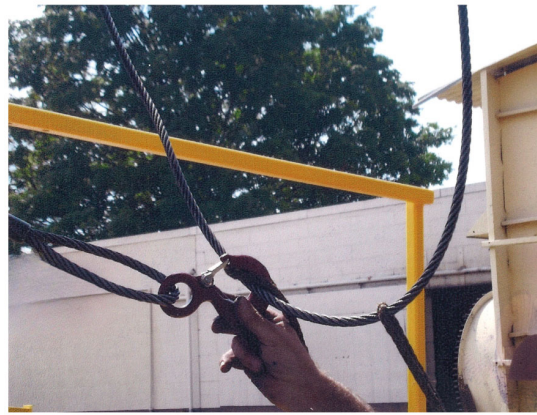
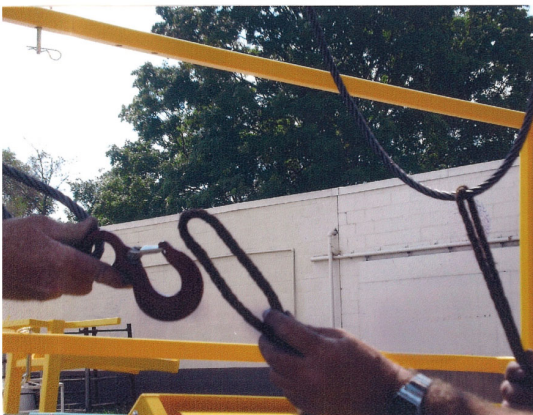



# MODEL: CT2710C-LT-SL

## SPECIFICATIONS

### DESCRIPTION

MODEL – CT2710C-LT-SC  
GVWR – 9,850 lbs.  
Empty Weight – 6,300 lbs.  
Carrying Capacity – 3,200 lbs.  
Overall Length – 27 ft.  
Overall Width – 96 in.  
Overall Height – 8 ft. – 4 in.  
Maximum Coil OD – 125 in.  
Minimum Coil ID – 48 in.  
Maximum Width – 66 in.

### RUNNING GEAR

Dual Axle – 5,200 lbs. Each  
Brakes – Electric  
Tires – ST225/75R15 LRD  
Wheels – 15 x 6 6 Bolt Mod  
Suspension – Slipper Leaf Spring

### FRAME

Main Frame – Double Frame – 8 x 2 x 3/16" Tube  
6 x 4 x 3/16" Tube  
Coil Cage – 2 x 2 x 1/4" Square Tube  
Mast Uprights Inside – 6 x 2 x 3/8" Rect. Double Tube  
Mast Uprights Outer – 7 x 5 x 3/16" Rect. Tube  
Mast Rollers – 5" Sch. 40 Pipe  
Threading Rollers – 3 1/2" Sch 40 Pipe  
Interior Roller – 3 1/2" Sch 40 Pipe  
Tongue – 6 x 4 x 3/16" Tube with Pintle Eye  
Fenders – 12 ga.

### ELECTRICAL

Plug – 7 RV Molded Plug  
Wiring – Enclosed in Tube with Junction Box  
Lights – Standard LED

### SAFETY

Chains – 3/8 with Heavy Duty Hook & Safety Latch  
Breakaway – Battery, Battery Box and Switch  
Decals – Warning Decals and Reflective Tape

### INCLUDED ACCESSORIES

McElroy 4-6 in. LineTamer® (LT0048)

### FINISH

Sherwin-Williams Paint  
Industrial Urethane Yellow

### HYDRAULICS

Motor – 5.5 HP Honda Motor  
Hydraulic Winch  
Valve – One 1 Spool Valve and One 3 Spool Valve  
Hydraulic Arm Cylinder – 5 x 24 Tie Rod  
Interior Roller Cylinder – 2 x 12 in. Tie Rod  
Threading Roller Cylinder – 2 1/2 x 6 in. Tie Rod

### AVAILABLE OPTIONS

Optional McElroy 2" LineTamer® (LT0122)  
Optional 2" LineTamer® Mount 9 (LTMI)  
Optional 3" Re-Round Kit (LT0037)  
Optional Hydraulic Operated Mast (HMI)





127 Industrial Park Rd, Sweetwater, TN 37874  
Office: 423.337.3466 · Fax: 423.337.7208  
www.pipetrailer.com

## Sweetwater Metal Products “Limited One (1) Year Warranty”

Sweetwater Metal Products – Sweetwater, TN 37874-3055, provides the following limited one (1) year warranty on products manufactured by it to the purchaser of such products and to any person to whom such product is transferred during the duration of this warranty.

The warrantor’s obligation shall be limited to repairing or replacing at the factory in Sweetwater, TN 37874, any part or parts which shall within the one (1) year period hereinafter specified be returned to it with transportation prepaid and which upon examination by Sweetwater Metal Products shows to have been defective. This warranty shall not apply if:

- (A) The product has been altered, repaired or modified outside the warrantor’s factory in any way that would adversely affect its operation.
- (B) The product has been subjected to misuse or damage while in the possession of the purchaser or any person to whom the product was transferred by the purchaser or was installed or operated other than in accordance with the manufacturer’s operating instructions.
- (C) The product was used with accessories not recommended by Sweetwater Metal Products or for loads in excess of those listed as rated for the product.

The one (1) year limited warranty period shall commence with the date the product is sold to the purchaser by the dealer or, if this date cannot be established, the date the product was sold by Sweetwater Metal Products.

The implied warranties of merchantability and fitness for particular purpose are limited to the duration of this warranty – one (1) year – after said one (1) year, Sweetwater Metal Products expressly disclaims any warranty of merchantability or fitness for any particular purpose.

Purchase or other acceptance of the product by the claimant shall be on the condition and agreement that Sweetwater Metal Products shall not be liable for incidental or consequential damages of any kind.

Sweetwater Metal Products shall not be liable for paint damage due to rock chipping.

Tires are not included under the one (1) year warranty and should the purchaser find them unsatisfactory, should make a claim directly to the tire manufacturer.

To make a claim under this warranty, write directly to Sweetwater Metal Products – 127 Industrial Park Rd – Sweetwater, TN 37874-3055, identifying the product and giving its location. Return instructions will be provided by the company. Sweetwater Metal Products will make its best efforts to repair or replace the products, if found to be defective within the terms of this warranty, within sixty (60) days after return of the product to the company.

In order to validate warranty, fill out the accompanying warranty registration card and return with ten (10) days from the date of purchase.